



Spare parts replacement instructions

# TCCAGE series

Bi-telecentric system for multiple side imaging and measurement at 90°

## Table of contents

Overview	.....	pag.	2
A. Replacement of SPMlxxx mirrors	.....	pag.	3
A.1 Disassembling and replacing	.....	pag.	3
A.2 Alignment	.....	pag.	5
A.3 Reassembling	.....	pag.	8
B. Replacement of SPPSxxx prism	.....	pag.	9
B.1 Disassembling and replacing	.....	pag.	9

## Overview

TCCAGE series contains delicate optical components such as mirrors and beam splitters which might get accidentally damaged. In such case, spare parts are available for fast replacement: follow the steps described in this manual to replace the damaged parts.

### Spare parts

### Calibrated samples



**SPMI001**  
First surface mirror,  
active area 20x40 mm,  
mount type 1



**SPMI002**  
First surface mirror,  
active area 20x40 mm,  
mount type 2



**SPMI003**  
First surface mirror,  
active area 25x75 mm,  
mount type 1



**CSCAGE048**  
Calibrated sample  
for alignment of  
TCCAGExx048

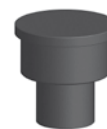

**CSCAGE096**  
Calibrated sample  
for alignment of  
TCCAGExx096



**SPPS001**  
Right angle prism, legs  
17 mm, H 39 mm, mirror  
coating



**SPPS002**  
Right angle prism, legs  
33.3 mm, H 72 mm,  
mirror coating

Refer to the drawings below to select the correct spare parts for your TCCAGE model.

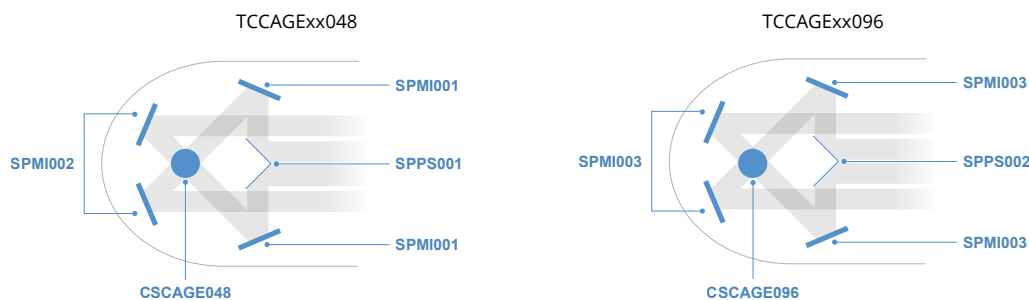

! Make sure to perform this procedure in a clean, dust-free environment in order to prevent dust or other particles from entering the optical system

## A. Replacement of SPMIxxx mirrors

### A.1 Disassembling and replacing

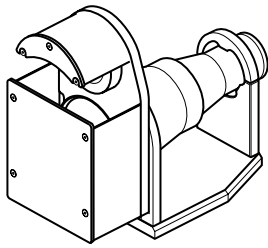

1

Position TCCAGE as depicted.

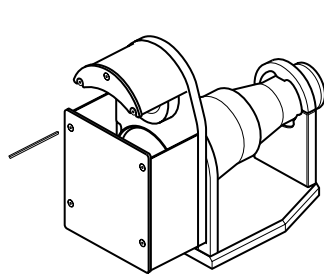

2

Remove the front and rear protective plates by loosening the screws

Front protective plate

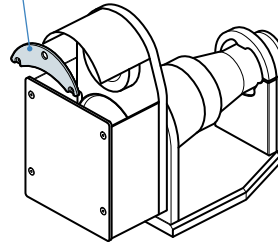

Rear protective plate

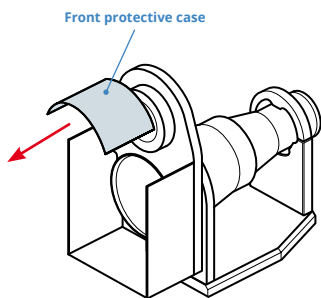
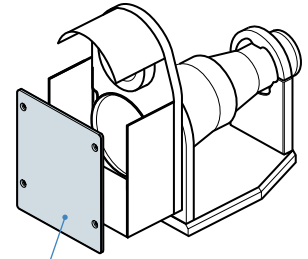

3

Remove the front protective case.

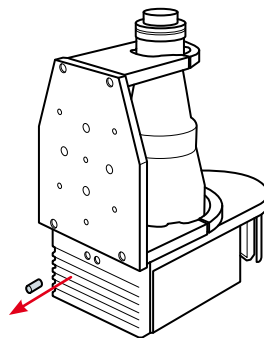

4

Position TCCAGE as depicted and remove the rear protective case by loosening the screws

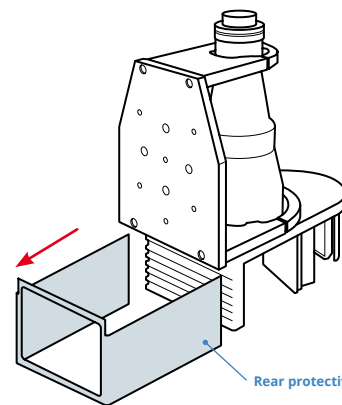

Rear protective case

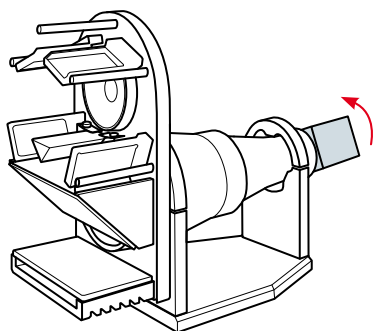

5

Position TCCAGE as depicted and screw the C-mount camera

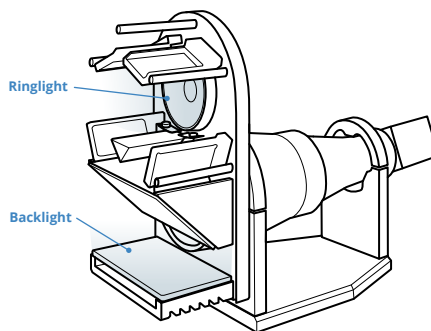

6

Turn the backlight and ringlight unit on.

Ringlight

Backlight

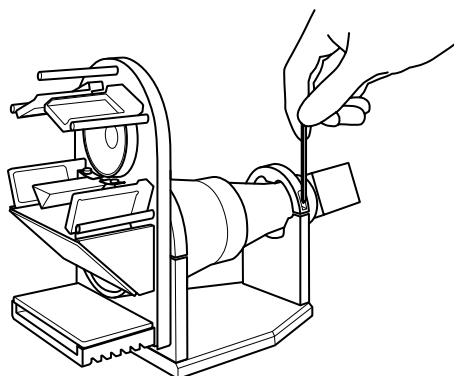
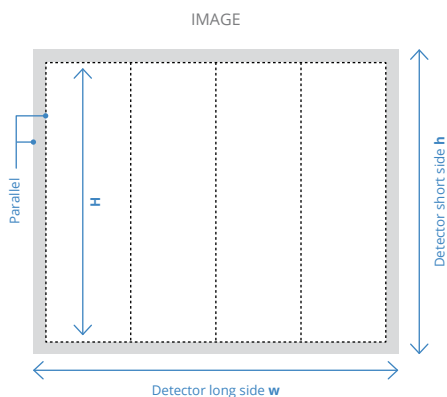

7

Verify that the longer side **H** of the four views (formed by the four mirrors) is parallel to the detector short side **h**.

8

If that is not the case, loosen the clamping mechanics to adjust the angular phase of the telecentric lens.

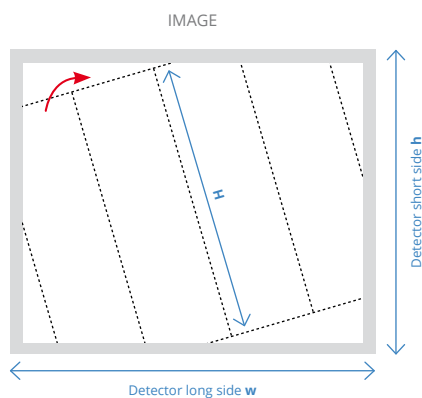
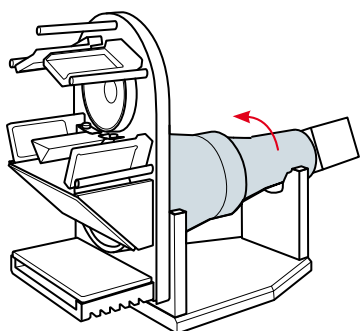

9

Rotate the telecentric lens until the longer side **H** of the four views (formed by the four mirrors) is parallel to the detector short side **h**.

TCCAGExx048 - upper plate top view

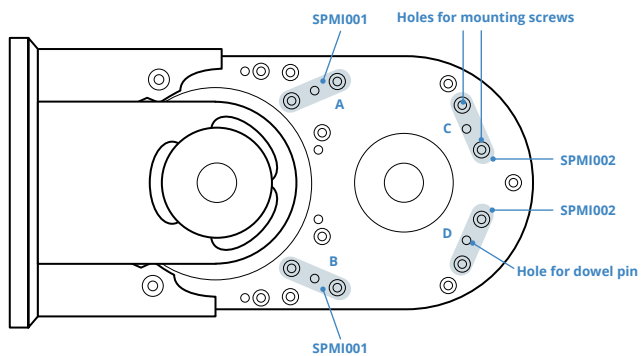

TCCAGExx096 - upper plate top view

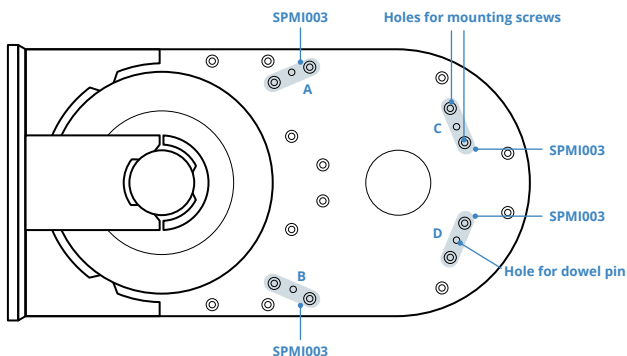

10

Loosen the two mounting screws of the damaged SPMIxxx

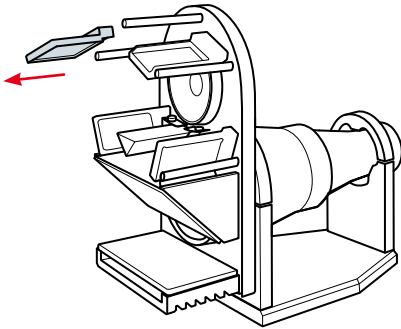

11

Remove the damaged SPMLxxx from the TCCAGE and the dowel pin

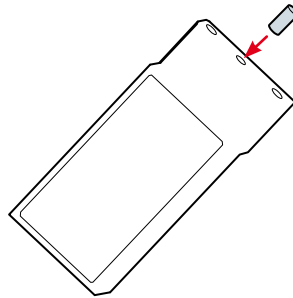

12

Pick up the new SPMLxxx and insert the dowel pin

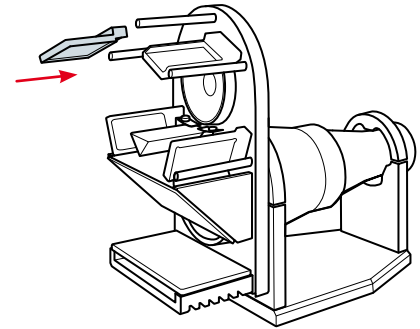

13

Place new SPMLxxx + dowel pin into its hole

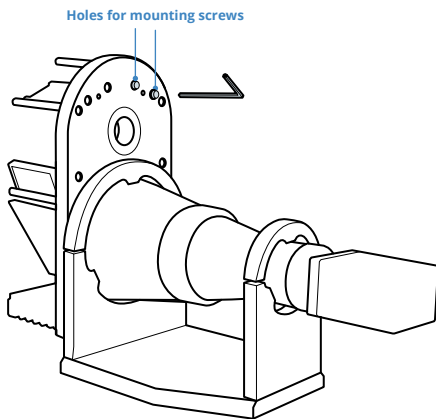

14

Screw the two mounting screws without tightening

## A.2 Alignment

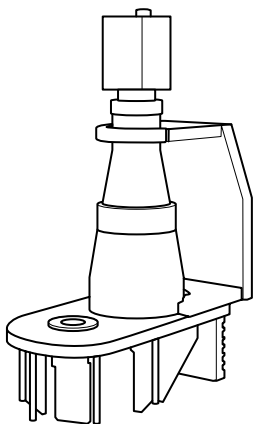

15

Position TCCAGE as depicted

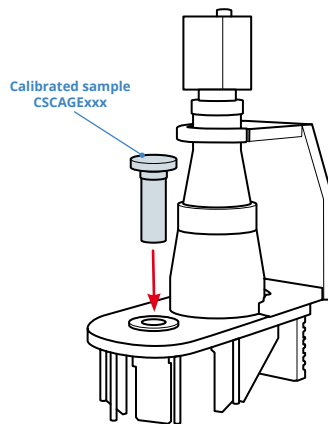

16

Insert the calibrated sample CSCAGExxx from the top hole.  
Use CSCAGE048 for TCCAGExx048, CSCAGE096 for TCCAGExx096.

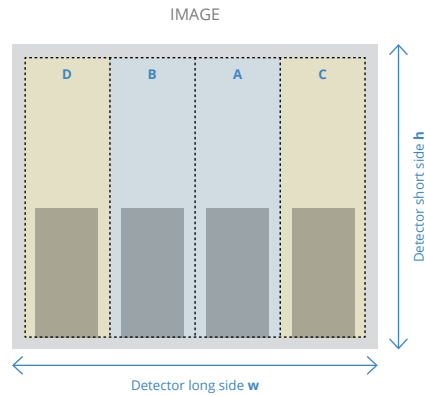
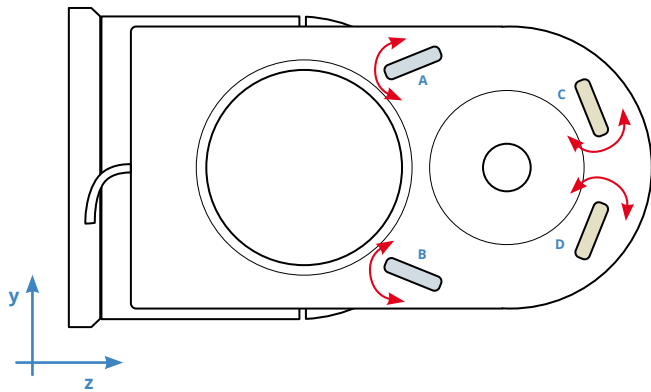

17

Adjust the orientation of SPMLxxx mirrors in the y-z plane, as prescribed in steps 18 and 19.

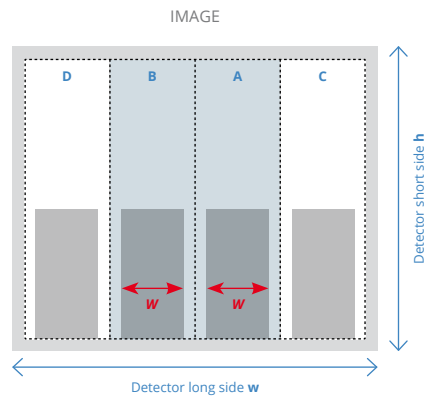
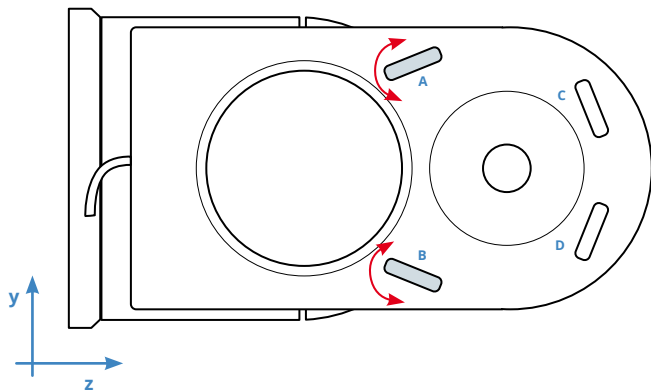

18

First, adjust the orientation of mirrors A and B (which make up the two central views) in the y-z plane by pivoting the mirrors around their dowel pins until both the central views **reach the same width** along the detector long side and tighten the mounting screws

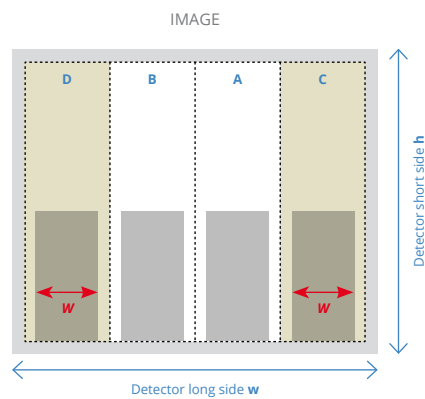
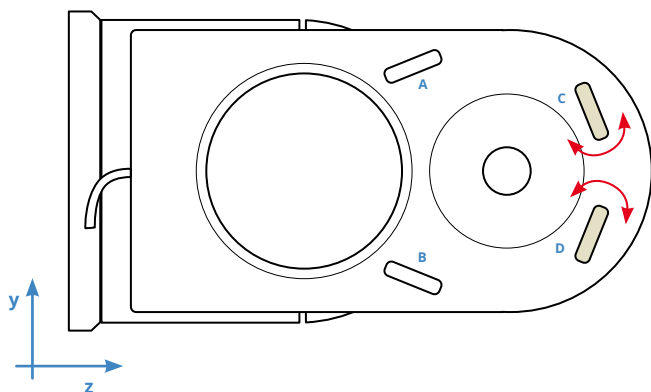

19

Second, adjust the orientation of mirrors C and D (which make up the two lateral views) in the y-z plane by pivoting the mirrors around their dowel pins until both the lateral views **reach the same width** along the detector long side (same width of views A and B) and tighten the mounting screws.

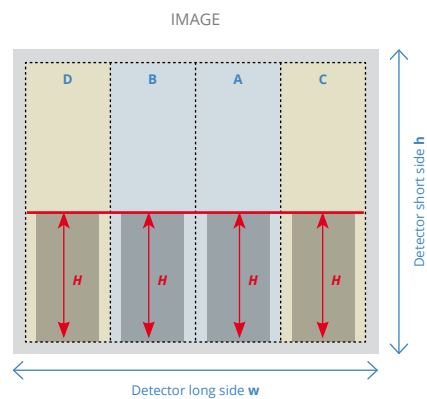
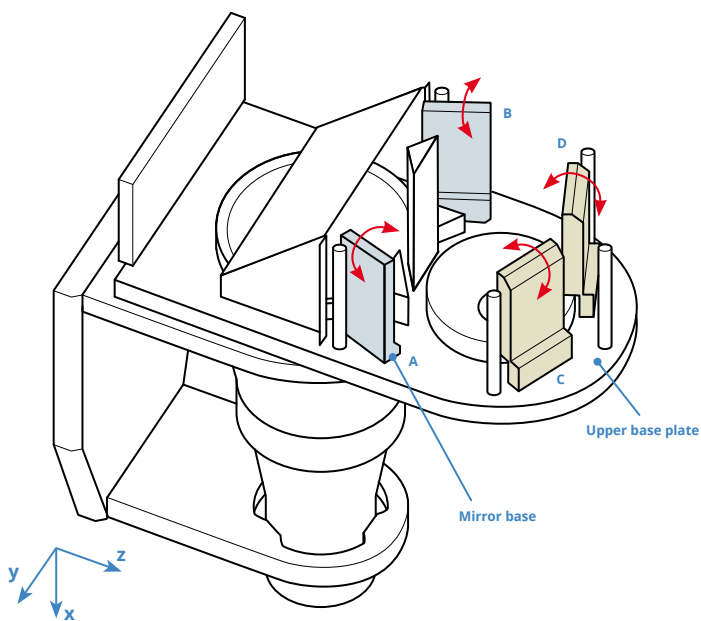

20

Adjust the tilt of mirrors SPMIxxx A, B, C and D as depicted by untightening the screws until the alignment sample **reaches the same height** in each view. While tilting the mirrors, take care not to misalign them in the y-z plane (see steps 17-19). To adjust the height of each view, place the appropriate number of spacers (not supplied) between the upper plate and the mirror bases. Use commercial shim tape of thickness 0.05 mm (not supplied) and tweezers (not supplied) to position it.

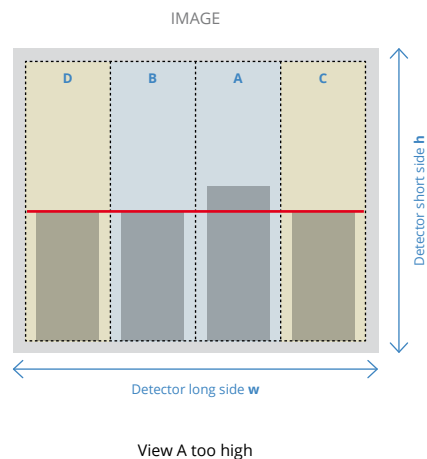
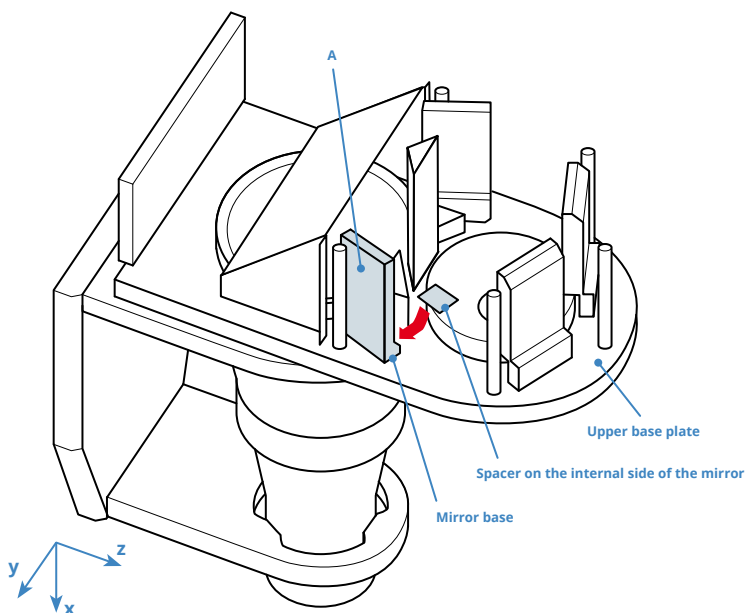

21

In case the height of the view is too high, position the appropriate number of spacers on the **internal side** of the mirror between the upper plate and the base of the mirror to lower the height



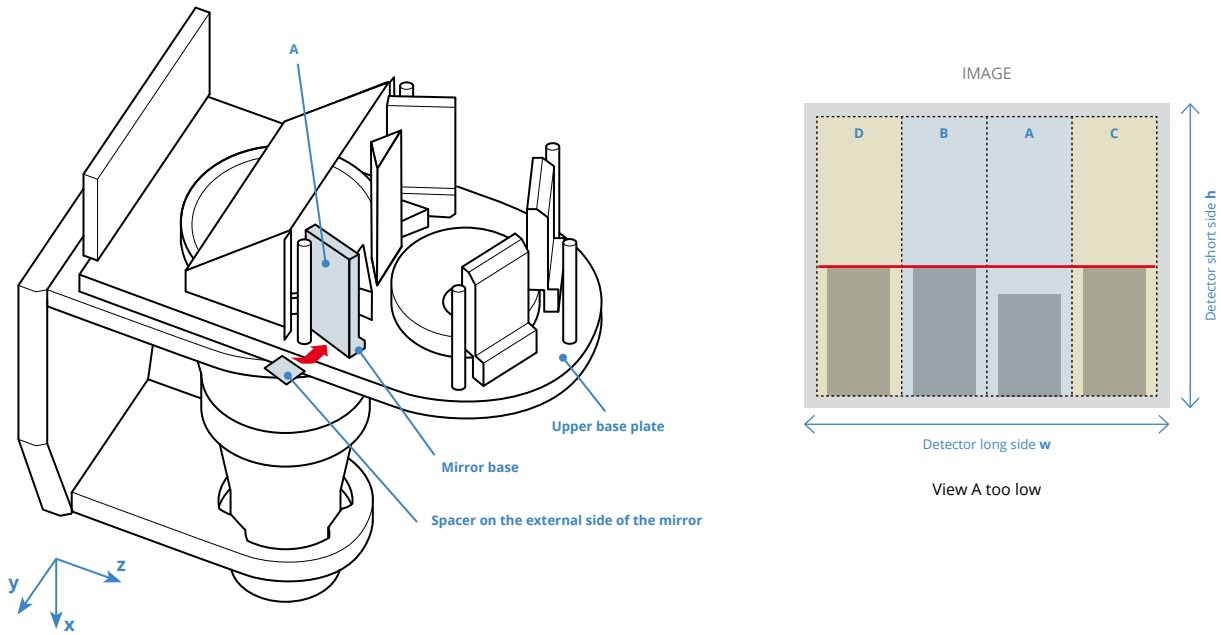

22

In case the height of the view is too low, position the appropriate number of spacers on the **external side** of the mirror between the upper plate and the base of the mirror to increase the height

### A.3 Reassembling

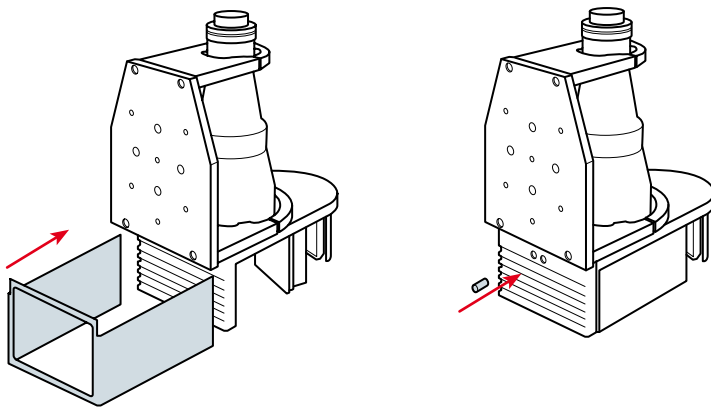

23

Position TCCAGE as depicted, insert the rear protective case and lock it in place by tightening the screws

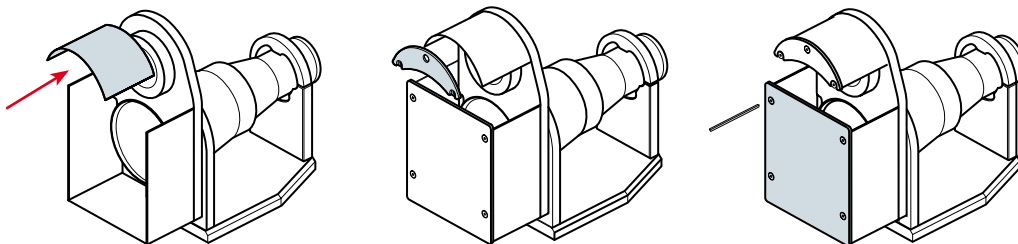

24

Insert the front protective case into its slit.

25

Position the front and rear protective plates and lock them in place by tightening the screws.

**!** Make sure to perform this procedure in a clean, dust-free environment in order to prevent dust or other particles from entering the optical system

## B. Replacement of SPPSxxx prisms

### B.1 Disassembling and replacing

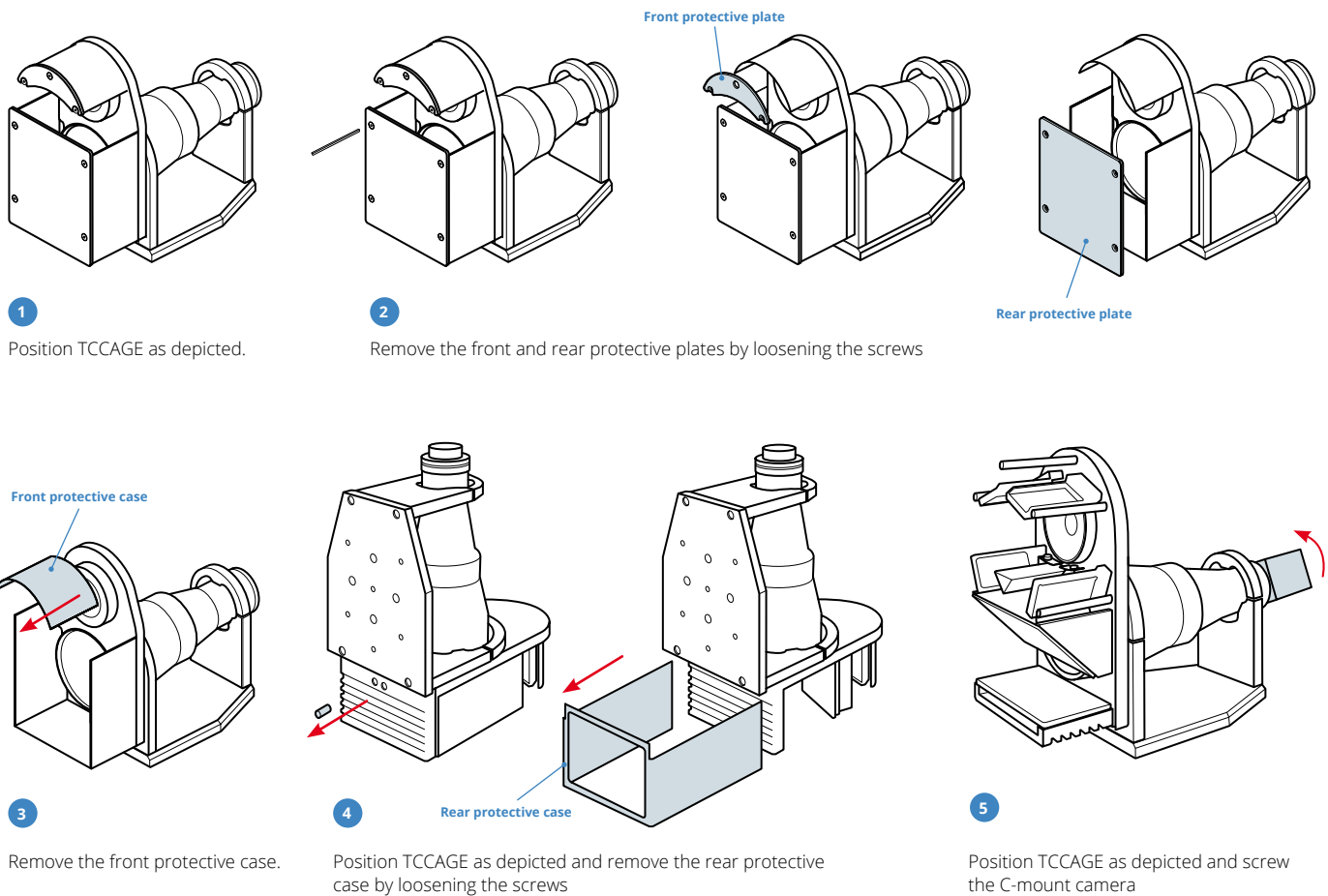

TCCAGExx048 - upper plate top view

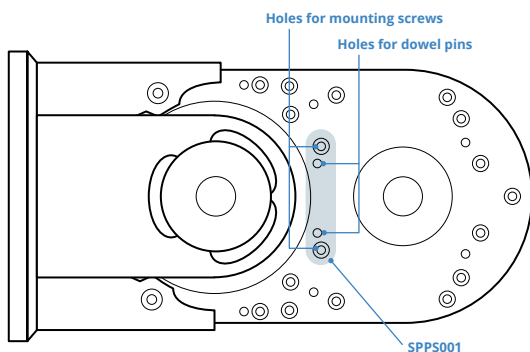

TCCAGExx096 - upper plate top view

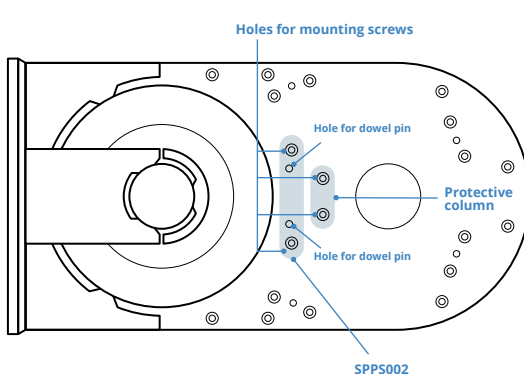

**6** Loosen and remove the two mounting screws of the damaged prism SPPSxxx. TCCAGExx096 features an additional protective column which must be removed first by unscrewing the screws.

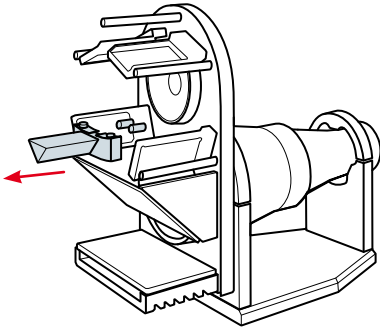

7

Remove from the TCAGE the damaged SPPSxxx and dowel pins.

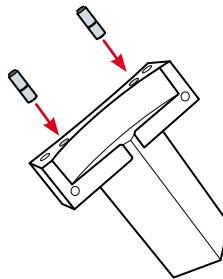

8

Pick up new SPPSxxx and insert the two dowel pins

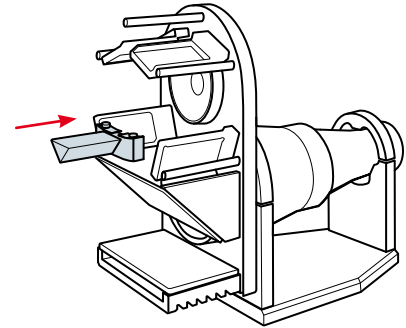

9

Place new SPPSxxx + dowel pins into their holes

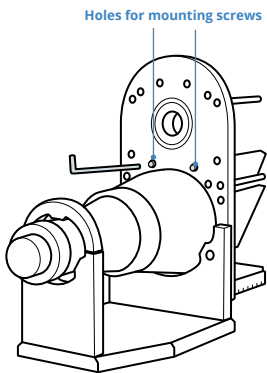

10

Screw the two mounting screws. After placing SPPSxxx, check the alignment of the four views (formed by the four mirrors); correct if necessary.

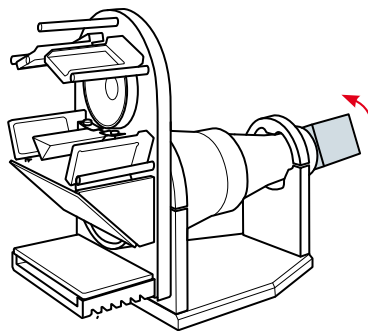

11

Position TCCAGE as depicted and screw the C-mount camera

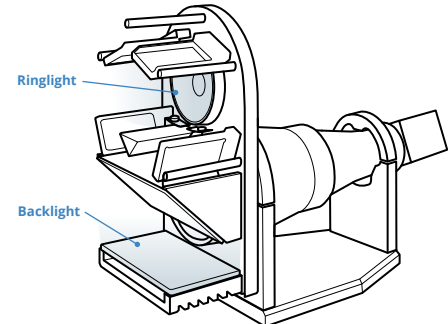

12

Turn the backlight and ringlight unit on

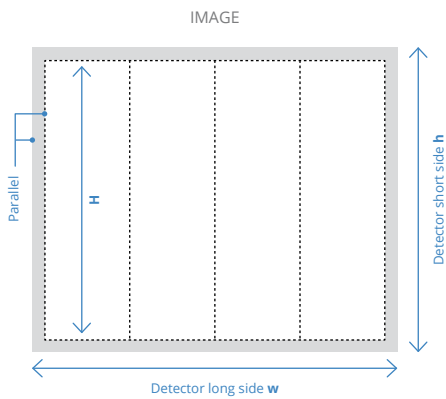

12

Verify that the longer side **H** of the four views (formed by the four mirrors) is parallel to the detector short side **h**.

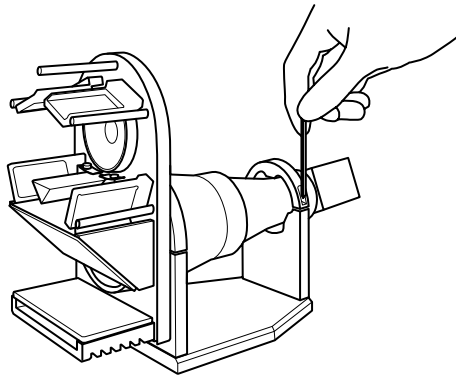

13

If that is not the case, loosen the clamping mechanics to adjust the angular phase of the telecentric lens.

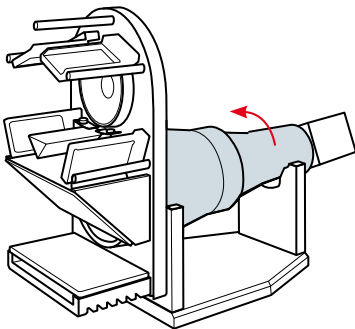

14

Rotate the telecentric lens until the longer side **H** of the four views (formed by the four mirrors) is parallel to the detector short side **h**.

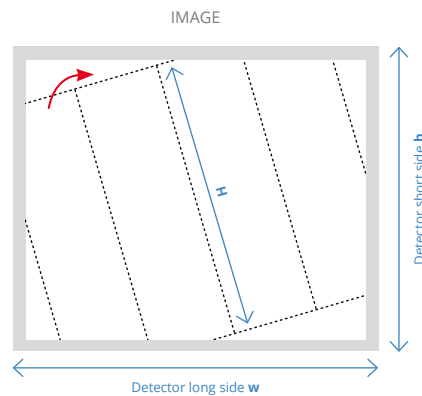

**In case of misalignment of the mirrors, follow instructions from sections A.2 and A.3 to align the mirrors and reassemble the TCCAGE.**

## Contact us

### EUROPE

**Opto Engineering  
Europe headquarters**  
Circonvallazione Sud, 15  
46100 Mantova, IT  
phone: +39 0376 699111  
contact@opto-engineering.com

**Opto Engineering  
Germany**  
Agnes-Pockels-Bogen, 1  
80992 München, DE  
phone: +49 0 89 18930918  
de@opto-engineering.com

### UNITED STATES

**Opto Engineering  
USA**  
11261 Richmond Ave  
Ste G-108 - Houston, TX 77082  
phone: +1 832 2129391  
us@opto-engineering.com

### ASIA

**Opto Engineering  
China**  
Room 2405, n°885, Renmin RD  
Huangpu District 200010  
Shanghai, China  
phone: +86 21 61356711  
info@deepview.cn

**Opto Engineering  
Japan**  
*official partner*  
Optart Corporation  
4-54-5 Kameido Koto-ku  
Tokyo, 136-0071 Japan  
phone: +81-3-5628-5116  
jp@opto-engineering.com

**Opto Engineering  
Korea**  
*official partner*  
Far Island Corporation, Ltd.  
Seoul, Korea  
phone: +82 70 767 86098  
+82 10 396 86098  
kr@opto-engineering.com